

STAR WARS

LEGION

AAT TRADE FEDERATION BATTLE TANK UNIT EXPANSION

To assemble the miniature, follow these steps:

- A. For each step, clip the labeled components from the frame and sort them.
- B. Assemble the miniature as indicated using super glue or plastic glue.
- C. Allow any glue used during assembly to dry.

1.

Begin assembly by gluing the missile tube inserts (A02–A07) into the upper half of the front hull (A01). When the inserts are properly aligned and glued in place, glue the lower half of the front hull (A08) to the upper half of the front hull.

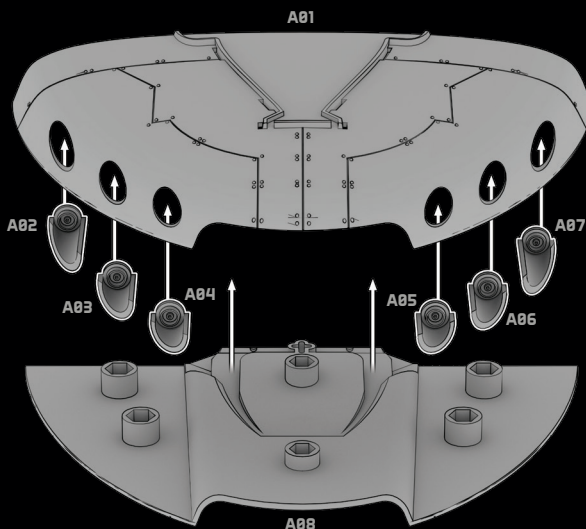

2.

Assemble the rear hull of the tank by first inserting the two interior panels (A10, A14) to the recessed areas inside the right half of the rear hull (A09).

With the interior panels in place, test fit and then glue the left half of the rear hull (A11) to the right half of the rear hull. Ensure that the halves are properly aligned and meet flush with one another.

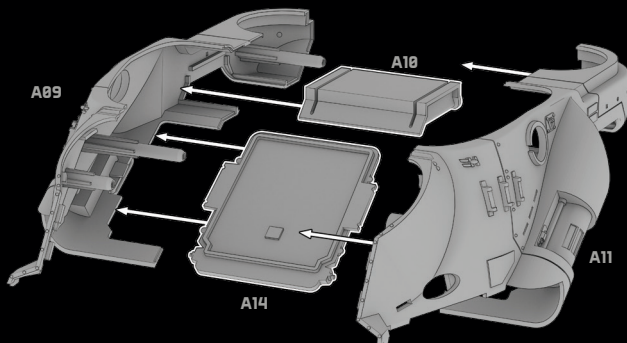

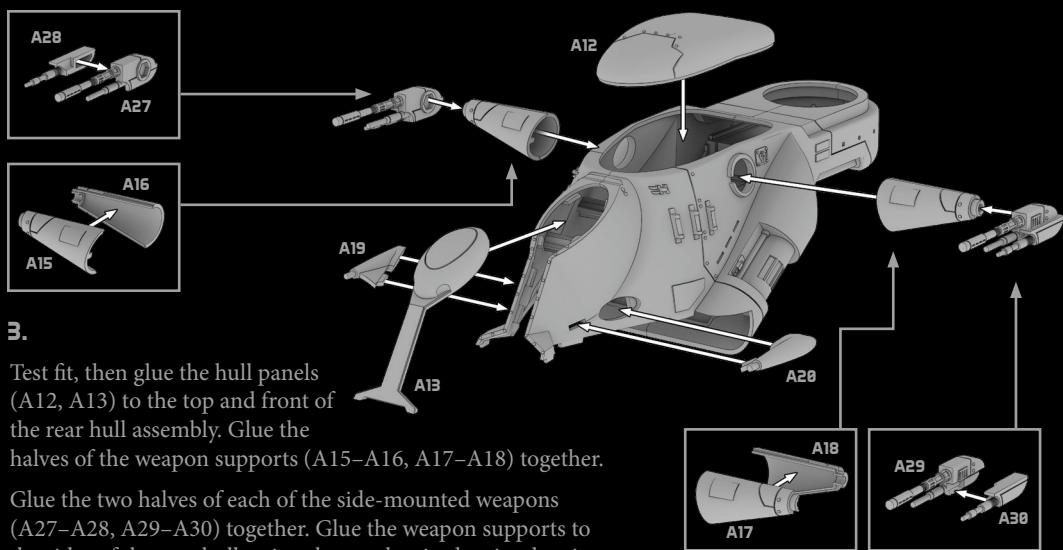

3.

Test fit, then glue the hull panels (A12, A13) to the top and front of the rear hull assembly. Glue the halves of the weapon supports (A15–A16, A17–A18) together.

Glue the two halves of each of the side-mounted weapons (A27–A28, A29–A30) together. Glue the weapon supports to the sides of the rear hull, using the notches in the circular rims on the side of the hull for alignment. Glue the weapons to the weapon supports and glue the side fins (A19, A20) to either side of the rear hull.

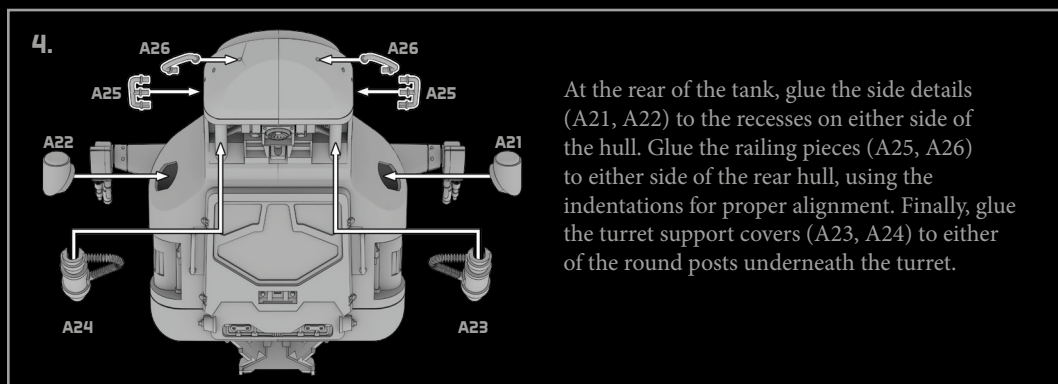

At the rear of the tank, glue the side details (A21, A22) to the recesses on either side of the hull. Glue the railing pieces (A25, A26) to either side of the rear hull, using the indentations for proper alignment. Finally, glue the turret support covers (A23, A24) to either of the round posts underneath the turret.

5.

Assemble the turret base by first gluing the top of the turret (A31) to the bottom of the turret (A32). Next, glue the three parts of the interior of the weapon mount together (A33–A35). Glue this subassembly to the bottom half of the weapon mount (A36). The rounded channel of each of these two parts should go over the round bar at the front of the turret base. If you want the weapon to be able to elevate, be careful to not get any glue over the round bar or the recesses. Glue the weapon (A37) to the hole at the front of the weapon mount and glue the weapon mount top hatch (A38) to the top of the weapon mount. Glue the turret details (A41–A44) to the recesses on the turret.

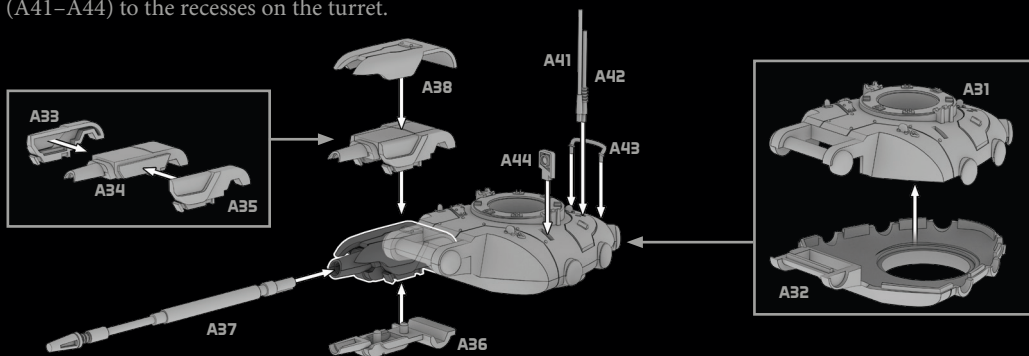

6.

We have supplied two hatch options for the tank. You can assemble the hatch:

A. Closed (A39, A40).

B. With B1 Battle Droid (A39, A40, B01–B09).

For the B1 Battle Droid option, first glue the round hinges on the hatch doors to the curved recesses on either side of the hatch. Next, assemble the miniature as indicated to the right and then glue the miniature to the recess inside of the hatch opening.

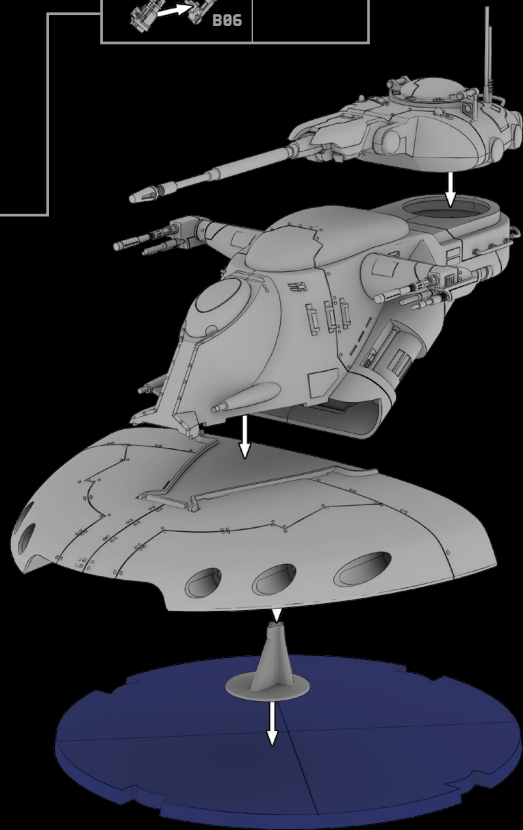
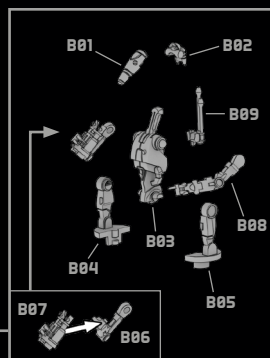
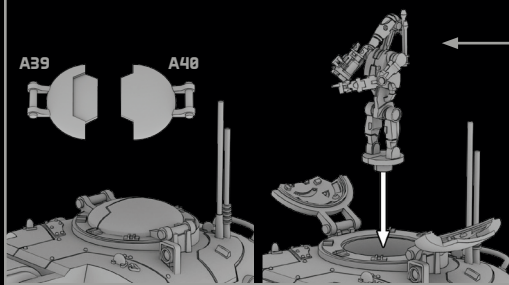

7.

Glue the rear hull assembly to the front hull assembly, using the alignment lines on the front hull as a guide. If you want the turret to rotate, do not glue it down to the recess in the rear hull assembly.

Test fit the peg to the bottom of the tank and align it on the base so the tank is in the desired position. We recommend allowing enough space to easily reach the notch at the front of the base with a movement tool. When happy with the placement, glue the peg to the base.

COMPONENT LIST

- 1 AAT Trade Federation Battle Tank Miniature with Base
- 1 Order Token
- 1 Aim Token
- 1 Dodge Token
- 1 Surge Token
- 1 Standby Token
- 3 Vehicle Damage Tokens
- 4 Wound Tokens
- 1 AAT Trade Federation Battle Tank Unit Card
- 8 Upgrade Cards
 - » 1 High-Energy Shells
 - » 1 Armor-Piercing Shells
- » 1 “Bunker Buster” Shells
- » 1 OOM-Series Droid Pilot
- » 1 T-Series Tactical Droid Pilot
- » 1 Lok Durd
- » 1 Linked Targeting Array
- » 1 HQ Uplink